

# PHONE JACKS

## 2.5mm SMT Jacks from Switchcraft

# PRODUCT BULLETIN 545

Switchcraft introduces a new series of 2.5mm jacks. These low profile jacks come in a wide variety of circuits, both 2 and 3 conductor versions. Circuits include mono closed, stereo open, stereo tip closed and ring open, and stereo closed. The MDSMT Series is available on tape and reel only. Contact Switchcraft for exact dimensions of the reels. They're designed for use in today's electronic equipment that features remote speakers, headsets, and headphones. While they are more compact than commonly used PC mount phone jacks, they are still extremely durable.

### Features and Benefits

---

- SMT mounting
- Tape and reel packaging
- Wide variety of circuits

### Applications

---

- Computer
- Video Cameras
- Personal/Portable Audio Devices
- Multimedia

### Specifications

---

#### Electrical

Current Rating: 3A  
Contact Resistance: <50 mohms  
Insulation Resistance: 100 mohms (min.)  
Dielectric Withstanding Voltage:  
250VAC @ 1 minute

#### Mechanical

Lifecycles: 5,000  
Operating Temperature: -25°C to +85°C

#### Material

Housing: Black thermoplastic  
Sleeve, Ring and Tip Terminals: Copper Alloy,  
silver-plated  
Shunt Terminal: Copper Alloy, Silver-plated

| Part Number | Description                              |
|-------------|--|
| MDSMT2BRATR | Stereo, dual open circuit                |
| MDSMT2ARATR | Mono, closed circuit                     |
| MDSMT3BRATR | Stereo, tip closed and ring open circuit |
| MDSMT4BRATR | Stereo, dual closed circuit              |

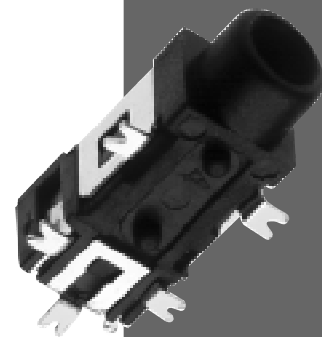

# 2.5mm SMT PHONE JACKS PRODUCT BULLETIN 545

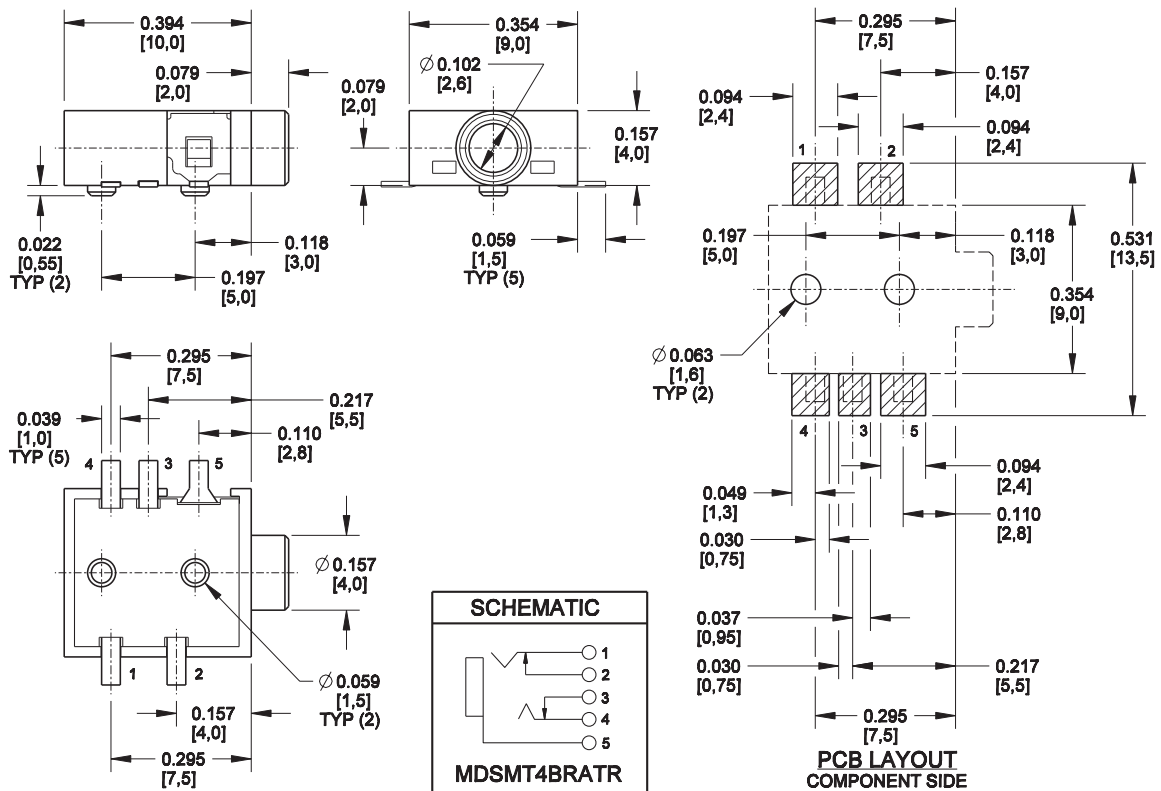
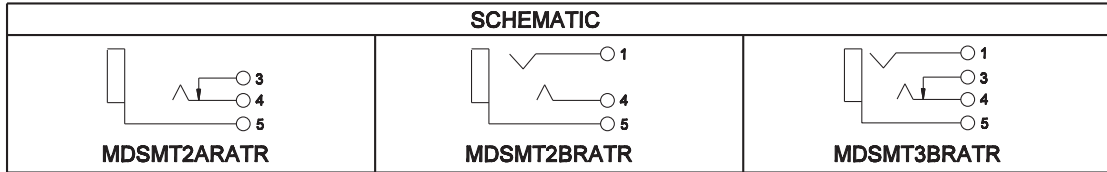
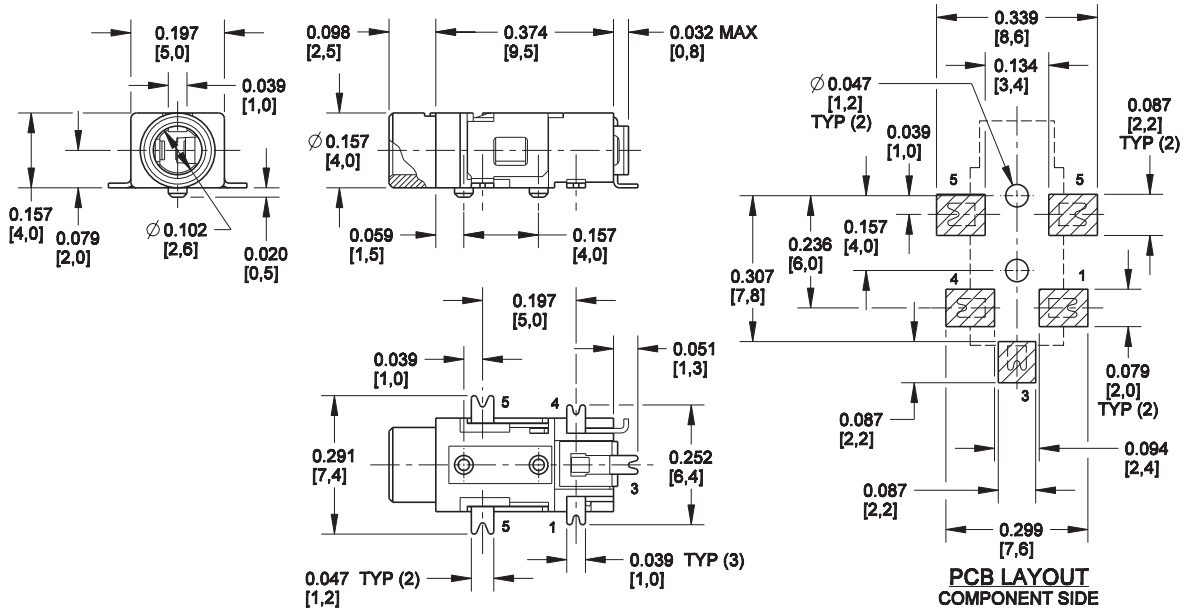

DIMENSIONS ARE FOR REFERENCE ONLY  $\frac{\text{Inch}}{\text{mm}}$   
All PC Board layouts are component side