



CONSOLES WITH SLOPING TOP MODEL QMA

Control console in AISI 304 stainless steel (Wnr 1.4301) with 12-degree sloping top complete with gas struts. One-piece shell with fixed rear panel. Fixed internal mounting plate in 25/10 FeZn. Mounting plate with front insertion on runners or upper insertion. IP 66 protection rating.

TECHNICAL DESCRIPTION

Type of steel: AISI 304 (Wnr 1.4301) Scotch-brite
Thickness: 1.5 mm (0.06")
Door: solid
Door fixing: hinges
Bottom door opening: 120°
Gasket: polyurethane
Internal mounting plate: included, in FeZn 25/10
Closing system: 5 mm (0.06") chromed Zamak lock with double bit insert
Bottom: plain cable gland plate
Shell: one-piece
Sloping top: 90° opening
Inclination angle: 12°
Sloping top fixing: hinges

CUSTOMIZATION POSSIBILITIES

Dimensions: adaptable on request*
Thickness: adaptable on request*
Material: AISI 316L (Wnr 1.4404)
Finishes: SN Coarse brushed
Gasket: silicone*
* Check when placing order

ON REQUEST

stainless steel internal mounting plate
plinth

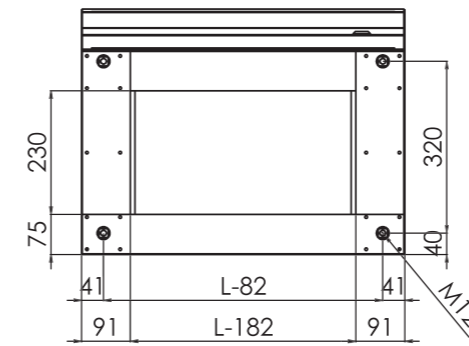

L = W (width)
H = H (height)
P = D (depth)

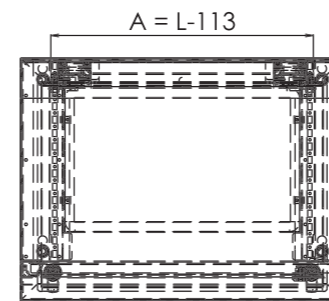
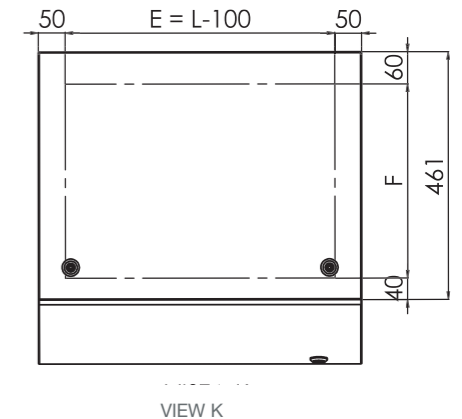
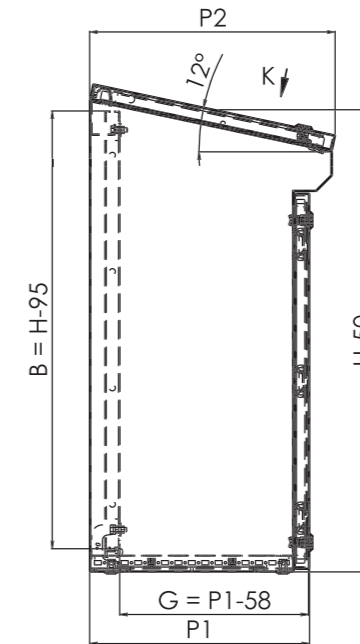
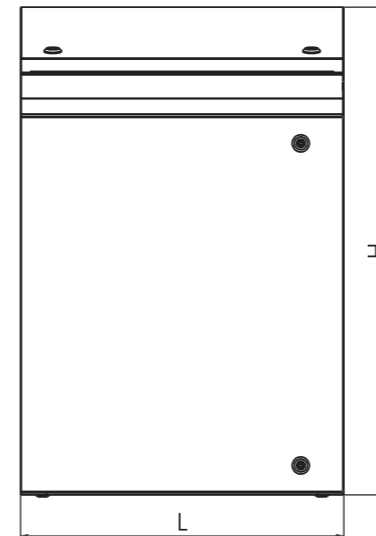

TECHNICAL DATA

internal mounting plate	W - 113 mm / H - 95 mm
sloping top drill size	W - 100 mm
usable depth	D - 58 mm

Model	Code	No. doors of lower section	External dimensions								Kg	m³	No. hinges	Internal mounting plate dimensions				Sloping top drill size		Usable depth		Certification				Model			
			W		H		D1		D2					A		B		E		F		G		IP 66 IK 10	IP 55 IK 10		UL type 1,12,4,4x	EX 3D 3G	
			mm	in.	mm	in.	mm	in.	mm	in.				mm	in.	mm	in.	mm	in.	mm	in.	mm	in.						
QMA 604	013410011	1	602	23.70	910	35.83	410	16.14	457	17.99	48	0,31	2	489	19.25	815	32.09	502	19.76	361	14.21	352	13.86	√		on request			QMA 604
QMA 804	013410021	1	802	31.57	910	35.83	410	16.14	457	17.99	59	0,42	2	689	27.13	815	32.09	702	27.64	361	14.21	352	13.86	√		on request			QMA 804
QMA 1004	013410041	1	1002	39.45	910	35.83	410	16.14	457	17.99	70	0,52	2	889	35.00	815	32.09	902	35.51	361	14.21	352	13.86	√		on request			QMA 1004
QMA 1204	013410061	2	1202	47.32	910	35.83	410	16.14	457	17.99	82	0,62	2 each door	1089	42.87	815	32.09	1102	43.39	361	14.21	352	13.86	on request	√	on request			QMA 1204
QMA 1404	013410081	2	1402	55.20	910	35.83	410	16.14	457	17.99	93	0,73	2 each door	1289	50.75	815	32.09	1302	51.26	361	14.21	352	13.86	on request	√	on request			QMA 1404
QMA 1604	013410101	2	1602	63.07	910	35.83	410	16.14	457	17.99	110	0,83	2 each door	1489	58.62	815	32.09	1502	59.13	361	14.21	352	13.86	on request	√	on request			QMA 1604